

Synchronous Disengaging SIKUMAT® SB ...

with double rollers

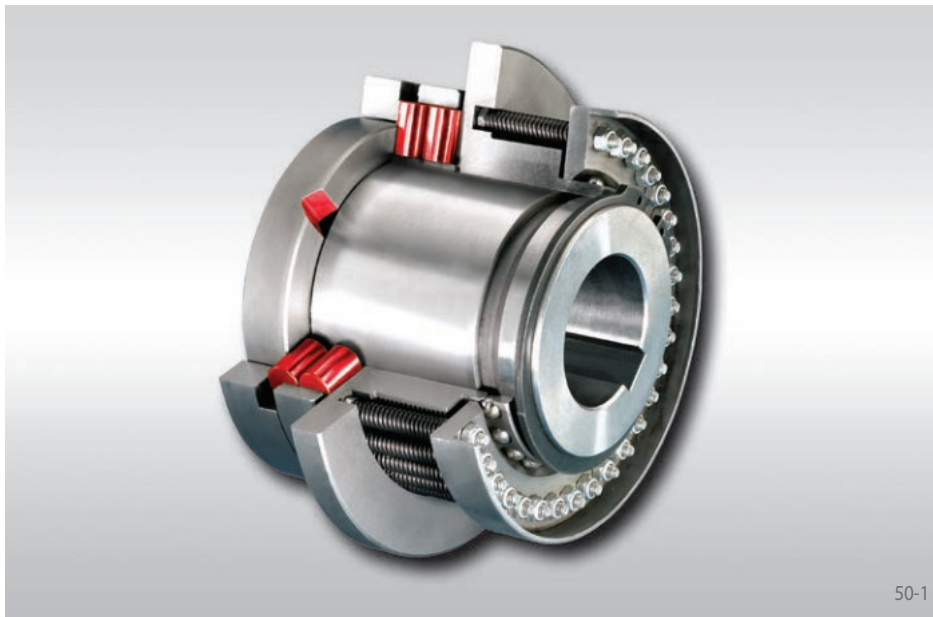

Advantages

- High degree of consistency of limit torque over the duration of operation through double roller principle
- Switching off in case of overload – separation of input and output
- Synchronous re-engagement after 360°
- Torques up to 10 000 Nm
- For shaft diameters up to 125 mm

The Double Roller Principle

The torque is transmitted via six pairs of rollers which are pressed by coil springs into detents. When the preset limit torque has been reached, the rollers move against the spring force up the sloping surface and disengage. This characteristic combined with the particular geometry of the detents provide a high degree of consistency to the limit torque of the SIKUMAT® over the duration of the operating period. Re-engagement is effected synchronously after 360° due to the asymmetrical division of the detents.

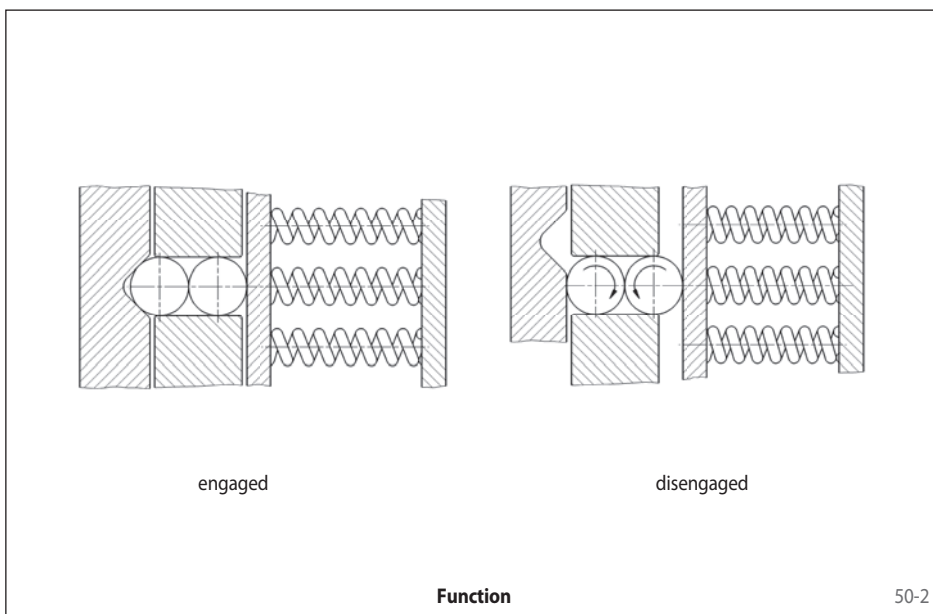

Function

- When the preset limit torque has been reached the SIKUMAT® effects a separation of input and output by means of a locking mechanism with integral bearings.
- Following elimination of the overload manual synchronous re-engagement of the SIKUMAT® to the starting position after 360°.
- This requires an axial switching force to be applied to the switching ring.

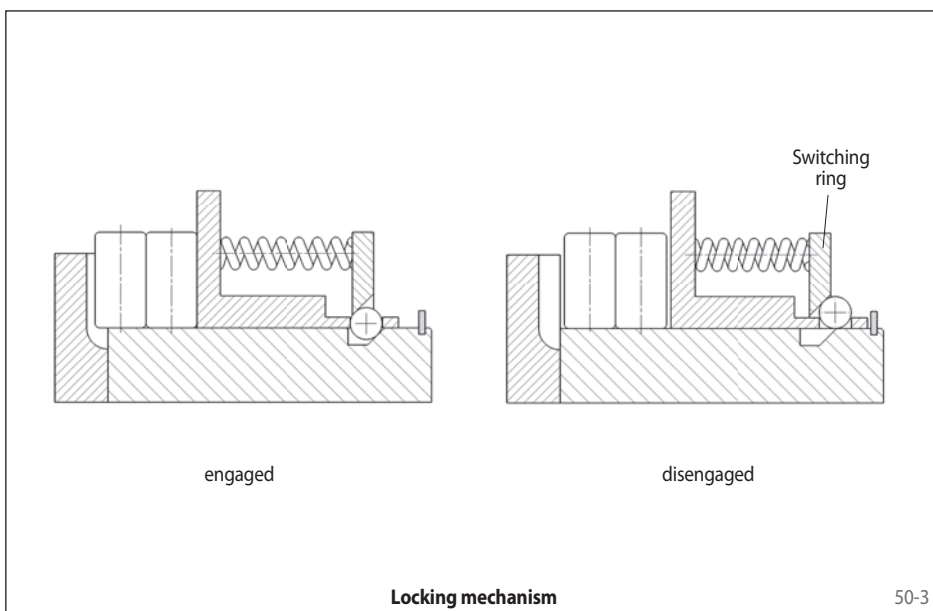

Synchronous Disengaging SIKUMAT® SB ...

with double rollers

Types

Series SB - Basic version with flange connection

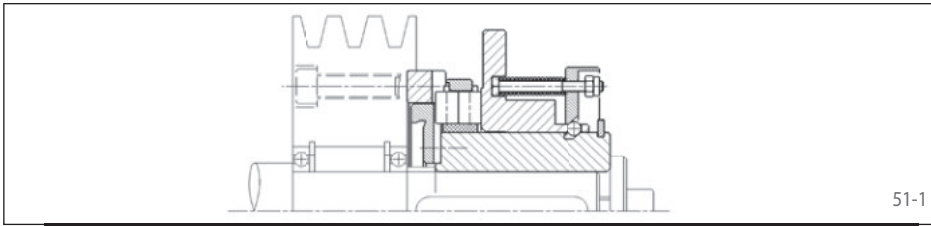

For attaching chain wheels, belt pulleys, gear wheels etc. Bearing of attached component on the shaft to be provided by the customer.

Page 52

Series SBG - with long hub

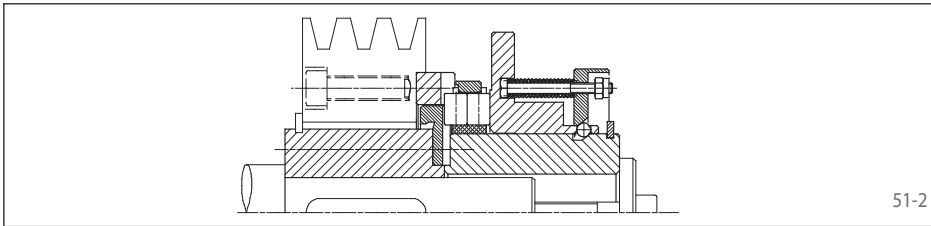

With long hub for wide connecting parts. Delivery includes plain bearing.

Page 53

Series SBE - with flexible shaft coupling

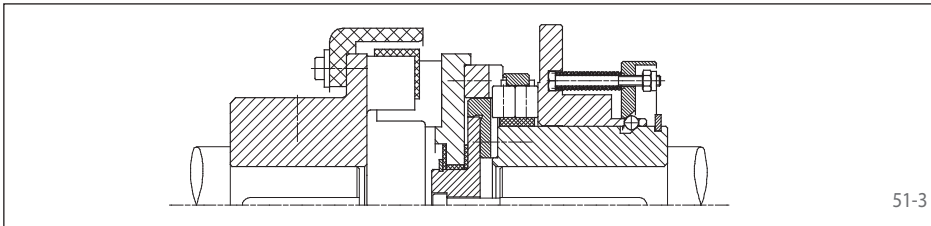

For flexible connection of two shafts. The flexible parts are oil-proof.

Page 54

Series SBL - with torsionally rigid shaft coupling

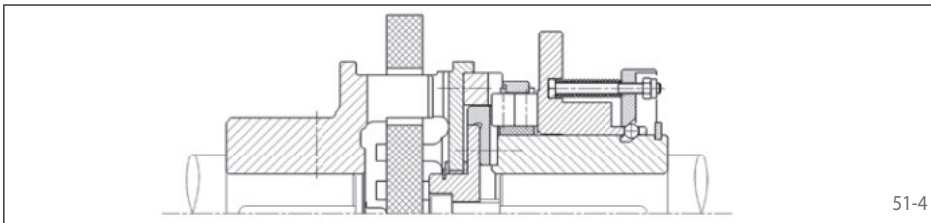

For torsionally rigid connection of two shafts. Possibility to compensate for large radial and angular displacements.

Page 55

Notes

Torque setting

The limit torque is normally set at the factory. Setting or modification of the limit torque can also be carried out by the customer but no unauthorised adjustment can be carried out by the machine operator. See operating instructions for further details.

Proximity switch

The overload can be indicated by a non-contact or a mechanical proximity switch. Further details on pages 62 and 63.

Synchronous Disengaging SIKUMAT® SB

with double rollers

Basic version with flange connection

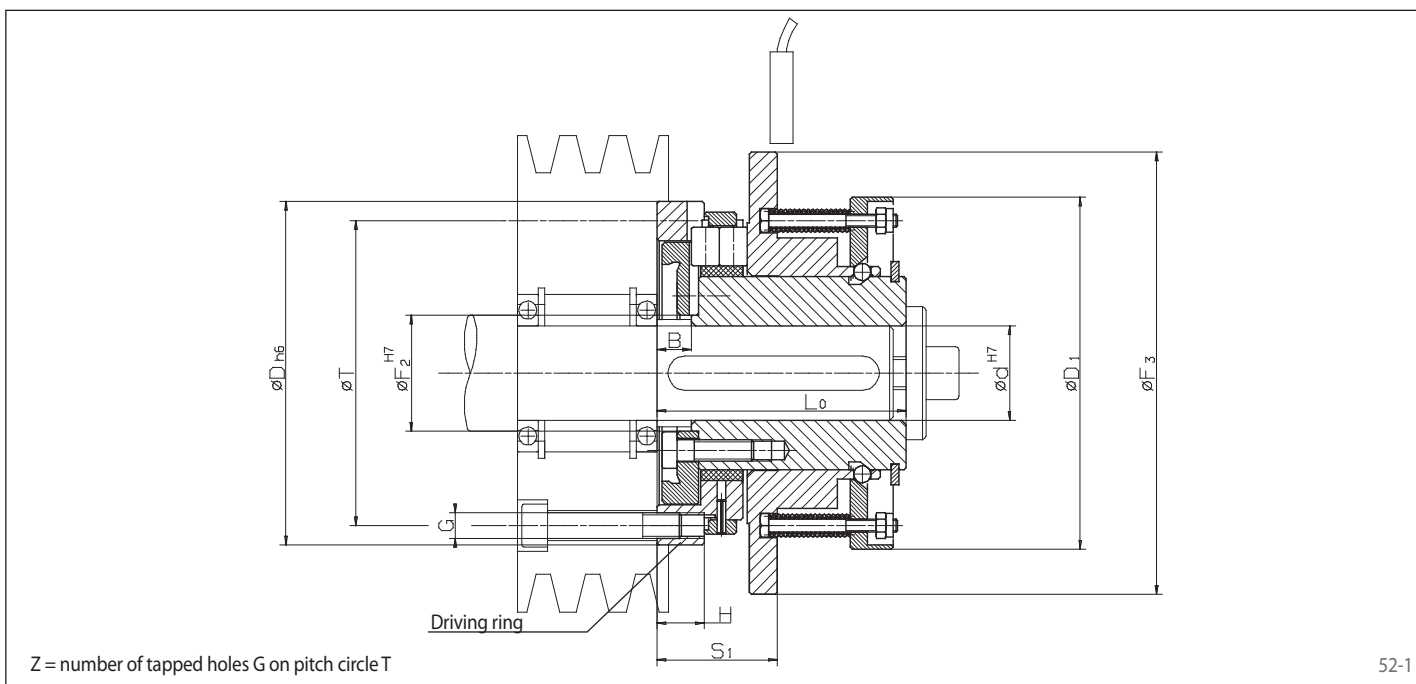

52-1

Technical Data

Type	Art.-No.	Limit torque Nm	max. speed min ⁻¹
SB 4	4470-004900	8 - 80	6000
SB 7	4470-007900	26 - 310	3800
SB 11	4470-011900	105 - 1250	2500
SB 14	4470-014900	210 - 2500	2100
SB 18	4470-018900	420 - 5000	1700
SB 22	4470-022900	840 - 10000	1300

Dimensions

Type	Art.-No.	Bore d		B	D	D ₁	F ₂	F ₃	G	H	L ₀	S ₁	T	Z	Engage-ment travel mm
		min. mm	max. mm												
SB 4	4470-004900	9	25	8	80	82	27	103	M 6	11	58	28	71	3	1,6
SB 7	4470-007900	25	40	10	125	125	43	150	M 8	19	90	43	109	3	2,5
SB 11	4470-011900	30	65	15	180	185	75	224	M 10	16	140	69	160	6	4,0
SB 14	4470-014900	50	80	20	224	224	95	272	M 12	18	180	87	200	6	5,0
SB 18	4470-018900	65	100	24	280	280	118	335	M 16	25	224	110	250	6	6,2
SB 22	4470-022900	80	125	30	355	355	150	412	M 20	30	280	140	315	6	8,0

Keyway as per DIN 6885, page 1 · Tolerance of keyway width P9

Example for Ordering

Type	Art.-No.	Preset limit torque	Bore d	with proximity switch
SB 4	4470-004 900	15 Nm	20 mm	See pages 62 and 63

Synchronous Disengaging SIKUMAT® SBG

with double rollers
with long hub

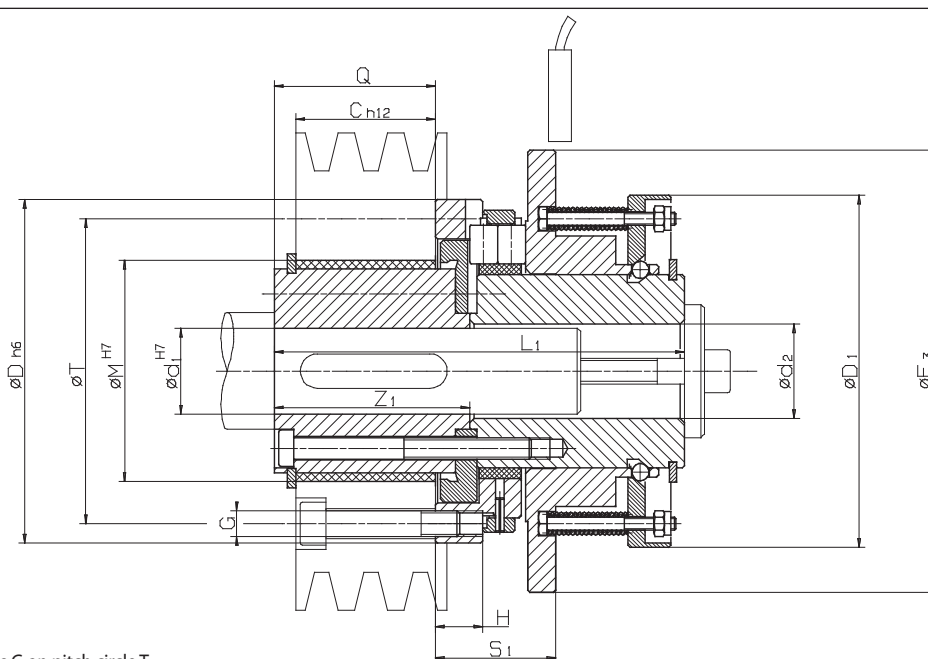

Z = number of tapped holes G on pitch circle T

53-1

Technical Data

Type	Art.-No.	Limit torque	max. speed
		Nm	min ⁻¹
SBG 4	4470-104900	8 - 80	6000
SBG 7	4470-107900	26 - 310	3800
SBG 11	4470-111900	105 - 1250	2500
SBG 14	4470-114900	210 - 2500	2100

Dimensions

Type	Art.-No.	Bore d ₁		C	D	D ₁	F ₃	G	H	L ₁	M	Q	S ₁	T	Z	Z ₁	Engage-ment travel
		min. mm	max. mm														
SBG 4	4470-104900	9	25	25	80	82	103	M 6	11	103	55	32	24	71	3	39	1,6
SBG 7	4470-107900	25	40	40	125	125	150	M 8	19	155	80	46	38	109	3	55	2,5
SBG 11	4470-111900	40	65	63	180	185	224	M 10	16	250	120	75	61	160	6	87	4,0
SBG 14	4470-114900	50	80	80	224	224	272	M 12	18	275	155	95	87	200	6	109	5,0

Bore d₂ is 0,2...0,5 mm larger than d₁ for sizes 4 - 7

Bore d₂ is 0,5...1,0 mm larger than d₁ for sizes 11 - 14

Keyway as per DIN 6885, page 1 · Tolerance of keyway width P9

Example for Ordering

Type	Art.-No.	Preset limit torque	Bore d ₁	with proximity switch
SBG 4	4470-104 900	15 Nm	18 mm	See pages 62 and 63

Synchronous Disengaging SIKUMAT® SBE

with double rollers
with flexible shaft coupling

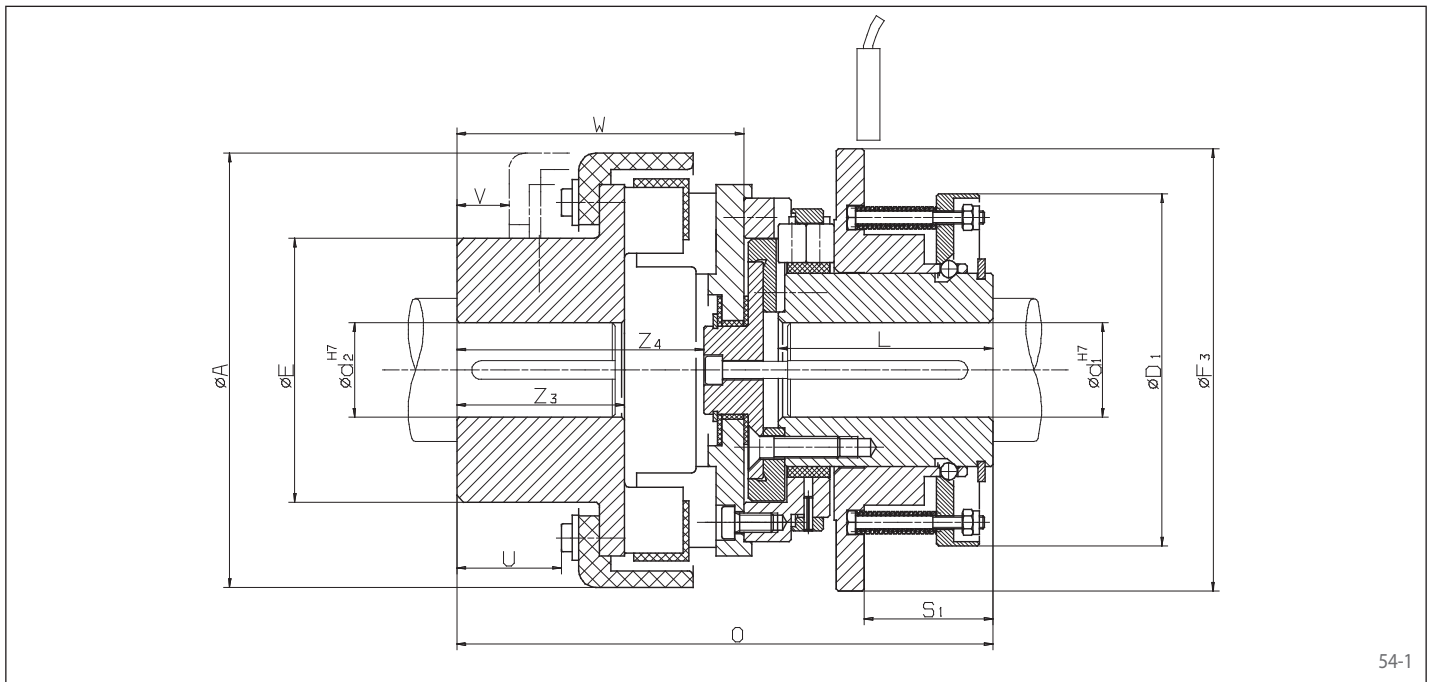

54-1

Technical Data

Type	Art.-No.	Limit torque Nm	max. speed min ⁻¹
SBE 4	4470-604900	8 - 80	6000
SBE 7	4470-607900	26 - 310	3800
SBE 11	4470-611900	105 - 1250	2500
SBE 14	4470-614900	210 - 2500	2100
SBE 18	4470-618900	420 - 5000	1700
SBE 22	4470-622900	840 - 10000	1300

Dimensions

Type	Art.-No.	Bore d ₁		Bore d ₂		A	D ₁	F ₃	E	L	O	S ₁	U	V	W	Z ₃	Z ₄	Engage-ment travel mm
		min. mm	max. mm	min. mm	max. mm													
SBE 4	4470-604900	9	25	5	45	114	82	103	72	50	133	30	28	19	75	41	63	1,6
SBE 7	4470-607900	25	40	20	60	158	125	150	96	80	202	47	39	21	112	61	97	2,5
SBE 11	4470-611900	30	65	25	80	230	185	224	130	125	283	71	49	21	143	82	124	4,0
SBE 14	4470-614900	50	80	45	100	294	224	272	160	160	359	93	56	17	179	97	153	5,0
SBE 18	4470-618900	65	100	60	120	330	280	335	195	200	430	114	80	25	206	116	179	6,2
SBE 22	4470-622900	80	125	75	160	432	355	412	255	250	563	140	104	31	283	160	247	8,0

Keyway as per DIN 6885, page 1 · Tolerance of keyway width P9

Example for Ordering

Type	Art.-No.	Preset limit torque	Bore d ₁	Bore d ₂	with proximity switch
SBE 4	4470-604 900	15 Nm	14 mm	30 mm	See pages 62 and 63

Synchronous Disengaging SIKUMAT® SBL

with double rollers
with torsionally rigid shaft coupling

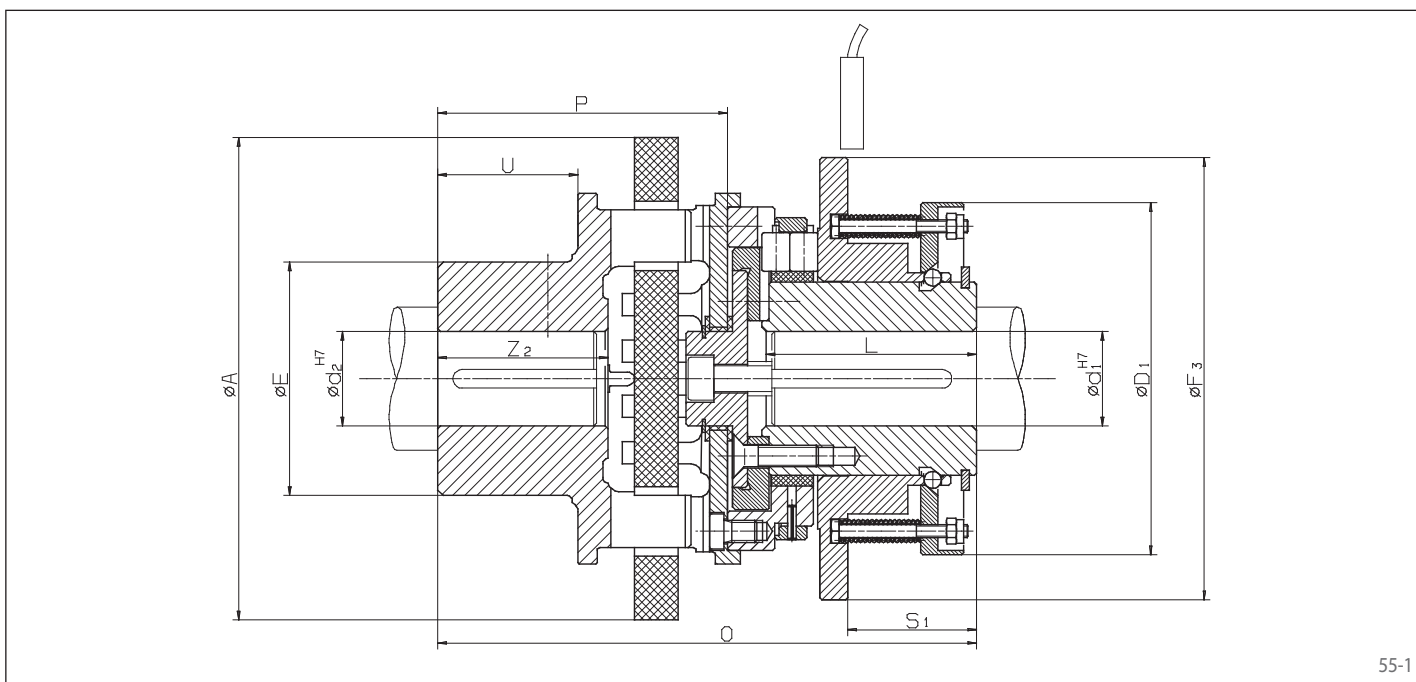

Technical Data

Type	Art.-No.	Limit torque Nm	max. speed min ⁻¹
SBL 4	4470-404900	8 - 80	4100
SBL 7	4470-407900	26 - 310	2670
SBL 11	4470-411900	105 - 1250	1700
SBL 14	4470-414900	210 - 2500	1350
SBL 18	4470-418900	420 - 5000	1350
SBL 22	4470-422900	840 - 10000	1050

Dimensions

Type	Art.-No.	Bore d ₁		Bore d ₂		A	D ₁	E	F ₃	L	O	P	U	S ₁	Z ₂	Engage-ment travel
		min. mm	max. mm	min. mm	max. mm											
SBL 4	4470-404900	9	25	16	35	110	82	53	103	50	135	77	33	30	42	1,6
SBL 7	4470-407900	25	40	30	50	160	125	85	150	80	195	105	51	47	62	2,5
SBL 11	4470-411900	30	65	50	90	250	185	150	224	125	300	160	81	71	100	4,0
SBL 14	4470-414900	50	80	60	110	315	224	175	272	160	384	204	101	93	124	5,0
SBL 18	4470-418900	65	100	60	110	315	280	175	335	200	462	238	101	114	124	6,2
SBL 22	4470-422900	80	125	75	140	400	355	216	412	250	600	320	130	140	160	8,0

Permissible radial displacement 0,015 x øA · Permissible angular displacement max. 3°
Keyway as per DIN 6885, page 1 · Tolerance of keyway width P9

Example for Ordering

Type	Art.-No.	Preset limit torque	Bore d ₁	Bore d ₂	with proximity switch
SBL 4	4470-404 900	23 Nm	11 mm	21 mm	See pages 62 and 63

Morskate®



Any questions? Please contact us.

Morskate Aandrijvingen BV

Oosterveldsingel 47A
7558 PJ Hengelo (Ov)
The Netherlands

NL

T +31 (0)74 - 760 11 11
info@morskateaandrijvingen.nl
www.morskateaandrijvingen.nl

DE

T +49 692 - 222 34 95
info@morskateantriebstechnik.de
www.morskateantriebstechnik.de

EN

T +31 (0)74 - 760 11 11
info@morskatedrivetechnology.com
www.morskatedrivetechnology.com